

**Duroplast**<sup>TM</sup>  
*where quality speaks for itself*



**Duroplast Furniture Systems Pvt. Ltd.**

Plot No.- 8, Phase - II, Kasba Industrial Estate ( Near Ruby General Hospital ) Kolkata - 700 107, West Bengal, India

P: +91 33 2443 0936/0937 | F: +91 33 2443 1176 | M: +91 9830058587  
E: admin@duroplastfurniture.com | web : www.duroplastfurniture.com

Ergonomic Commercial  
Furniture Solution



# COMPANY PROFILE

Duroplast Furniture Systems Pvt. Ltd. ventured into modular furniture production, & marketing since 2006. We bring a range of modular & metal office furniture, aluminum & glass partition, file storage, meeting conference tables, reception etc. We also customize home and commercial/ institutional furniture. As one of the most experienced and innovative modular furniture production companies in Kolkata, Duroplast enjoys a history of innovation and technology.

Duroplast is one such company which has followed latest trends in modular furniture and is always one step ahead in innovation and quality consciousness. The company believes in providing world class standard in its furniture range while reducing the production process as compared to conventional furniture with the use of standard machinery. A team of experienced professionals is always engaged in R & D of such furniture.

The company is presently having 20,000 sq. ft. manufacturing facility in Kolkata equipped with all the latest machineries. We at Duroplast are committed to retain our excellence in our range and service with utmost focus on customer satisfaction.

## RECEPTION



Make of pre-laminated engineering woods (Particle / MDF) of interior & exterior grade. Also make of post laminated plywood look of glossy/matte/suede finish. Corian and veneer work also done. Many more design also available.



CAD representation of standard design :

Std. size :  
 900x600mm  
 1200x600mm  
 1500x600mm  
 1800x750mm  
 2100x900mm  
 & many more

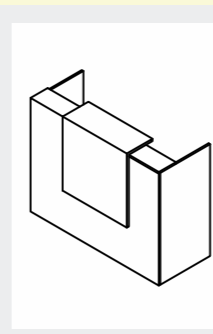

DP-RT-ECO

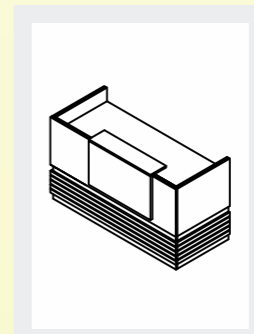

DP-RT-AMF

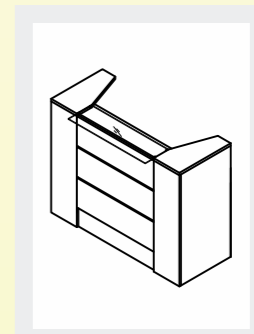

DP-RT-MDFN

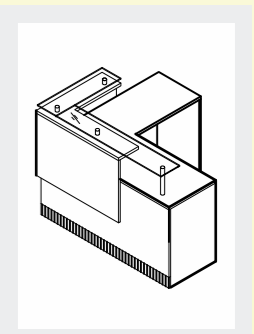

DP-RT-DPL



GREEN GUARD CERTIFIED



BIFMA - LEVEL 3 CERTIFIED



ISO 18001:2007 CERTIFIED



ISO 14001:2015 CERTIFIED



ISO 9001:2015 CERTIFIED

# FIGO series

## WIRE & SWITCH PLANNING

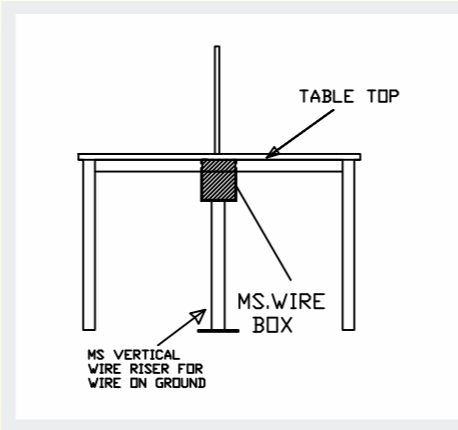
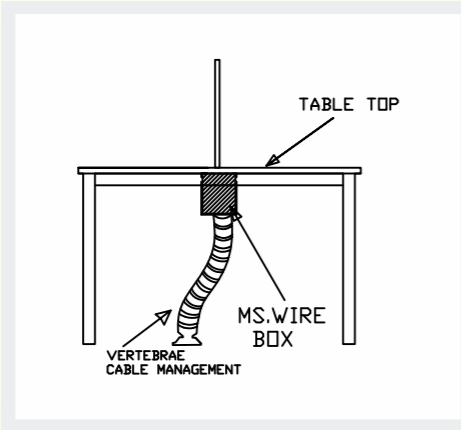
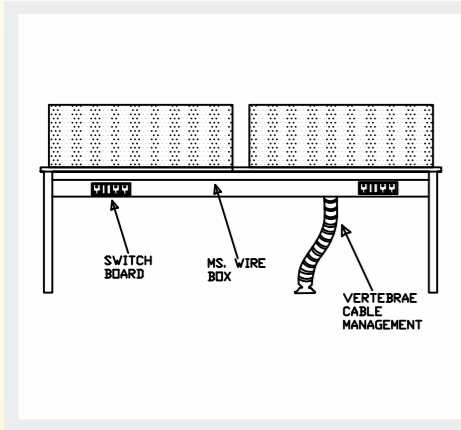
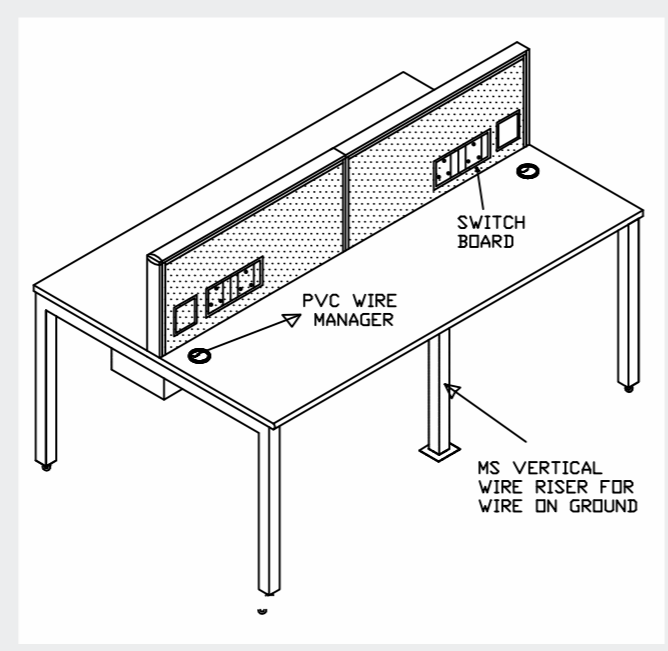
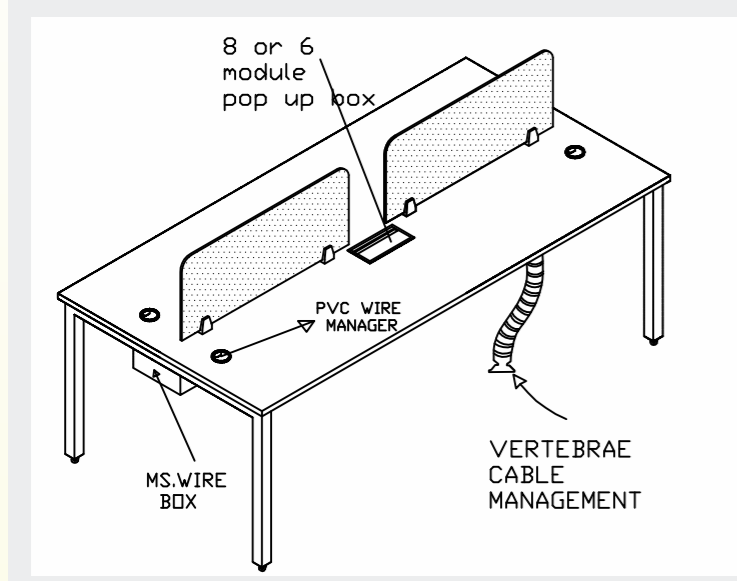

### Partition Option :

- Sandwich colour Writing & Magnetic
- Glass
- Soft Board
- Magnetic Soft Board
- Plain/Frosted Glass
- Aluminum Partition

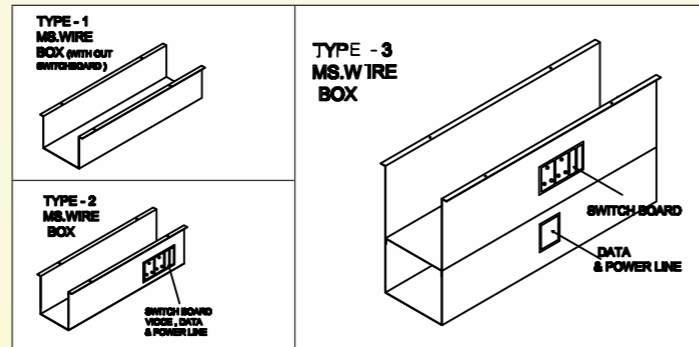

### Specification :

Prelaminated particle/MDF board top-25 mm duly PVC edge banded.

50X50mm steel powder coated under structure consist of connecting bar & legs. Also provided electric wire box of steel powder coated sheet.

# FIGO series



Figo series is free look desking arrangement. The clear design concept makes it easy to build your ideal workspace. Electric and network cable to run through carrying below.



### CAD representation of standard design :

Std. size :

- 900x600mm
- 1200x600mm
- 1500x600mm
- 1800x750mm
- 2100x900mm
- & many more

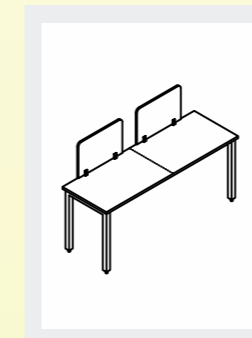

DP-FIGO-LT

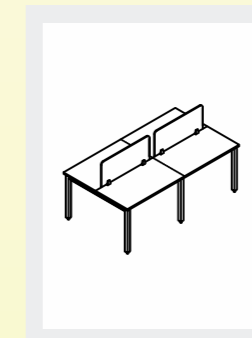

DP-FIGO-BLT

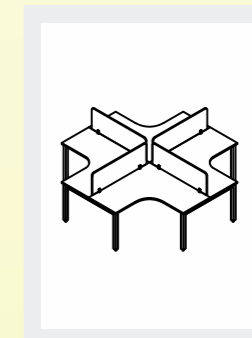

DP-FIGO-PLUS

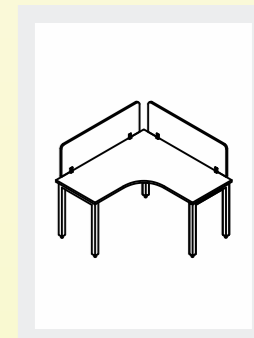

DP-FIGO-L

# 600 series

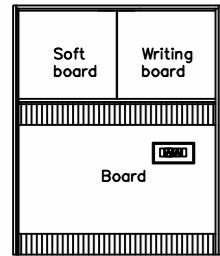
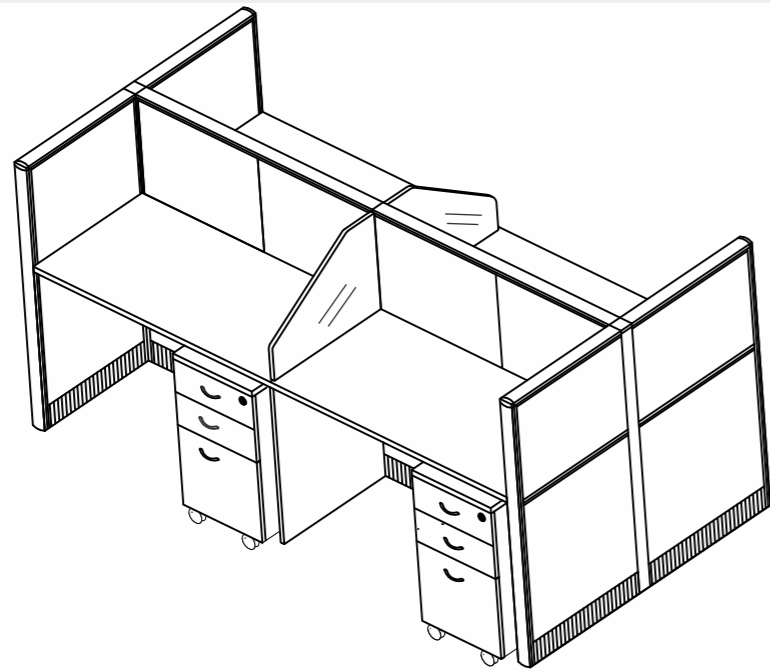

OPT-1

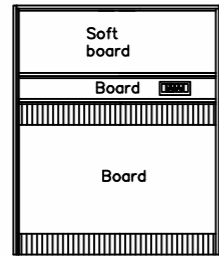

OPT-2

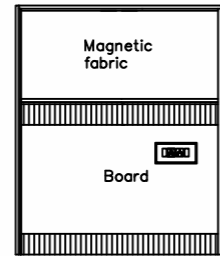

OPT-3

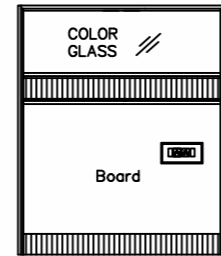

OPT-4

Soft Board, Writing Board, Writing Colour Glass, Magnetic Board & Glass, Plain/Frosted Glass available as required.

Made of codecrafted aluminum frame consisting of particle/MDF/SDF pre laminated boards. The frame has two level wire raceways for electrical & data management. Glass/Pin-up/Writing panel for front face of the frame.

## Electrical View

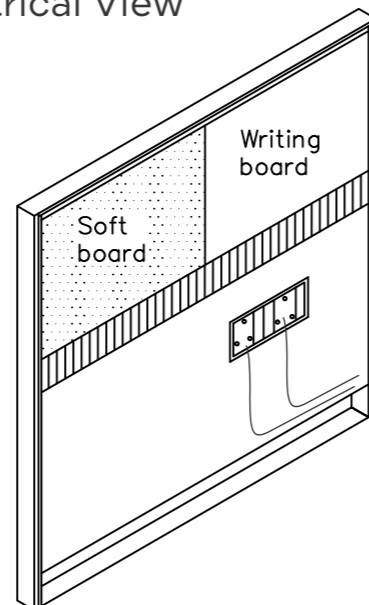

# 600 series



60mm thick panel based aluminum powder coated partition with sufficient internal wire management.



## CAD representation of standard design :

Std. size :

- 900x600mm
- 1200x600mm
- 1500x1500mm
- 1800x1800mm
- & many more

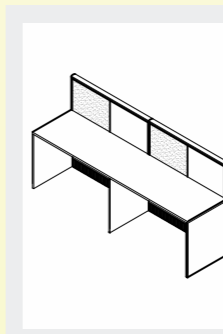

DP-600-LT

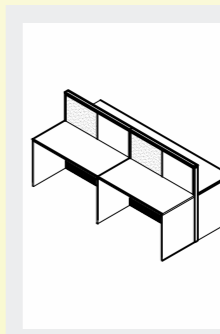

DP-600-BLT

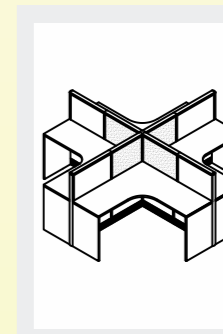

DP-600-PLUS

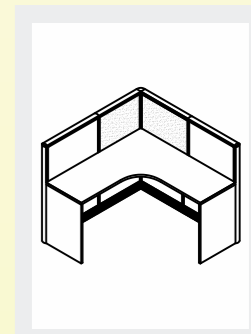

DP-600-L

# ECO series



Eco Series Is Free Look Desking Arrangement. The Clear Design Concept Makes It Easy To Build Your Ideal Workspace. Electric And Network Cable To Run Through Carring Below.



CAD representation of standard design :

Std. size :  
 900x600mm  
 1200x600mm  
 1500x600mm  
 1800x750mm  
 2100x900mm  
 & many more

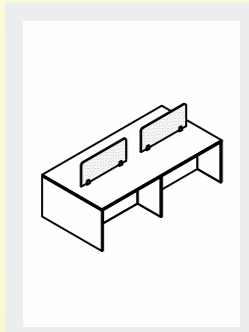

DP-ECO-BLT

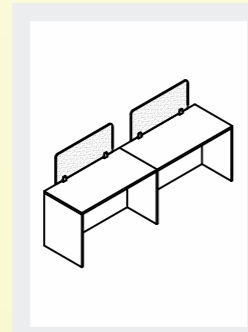

DP-ECO-LT

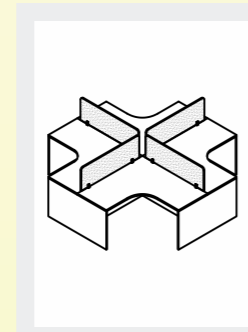

DP-ECO-PLUS

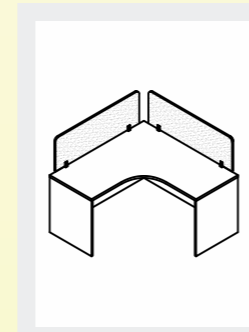

DP-ECO-L

# CUBICLE series



60mm thick panel base aluminum powder coated partition height 1200-1800mm. Top may be rectangular or "L" shaped. Side return unit and mobile drawer pedestal included. Many more designs also available.



CAD representation of standard design :

Std. size :  
 1350x1200x1200/750mm  
 1500x1200x1200/750mm  
 1500x1500x1200/750mm  
 1500x1800x1200/750mm  
 1350x1200x1200/750mm  
 1350x1350x1200/750mm  
 1500x1500x1200/750mm  
 & many more

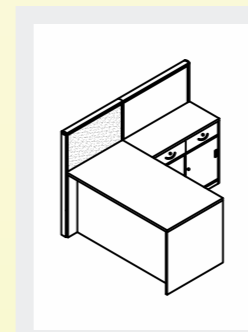

DP-CBCL-1

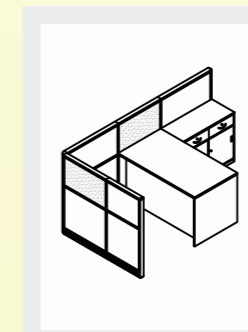

DP-CBCL-2

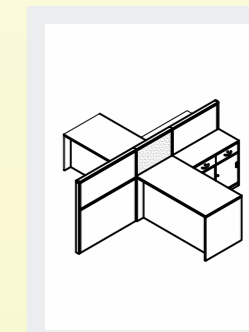

DP-CBCL-3

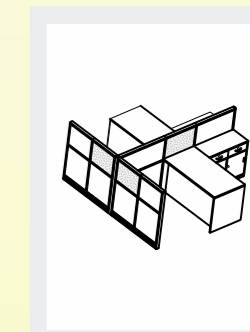

DP-CBCL-4



# CONFERENCE / MEETING tables



Tables made of high quality MDF/Particle boards with wooden & steel understructure. Size as per clients requirement. Corian and veneer work also done. Many more design also available.



CAD representation of standard design :

Std. size :  
 2400x1200mm  
 3000x1200mm  
 1800x900mm  
 2100x900mm  
 & many more

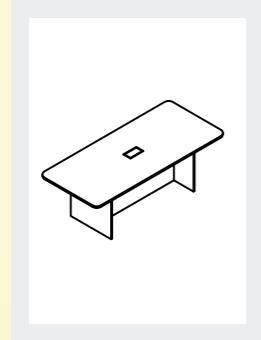

DP-MT-SQUARE

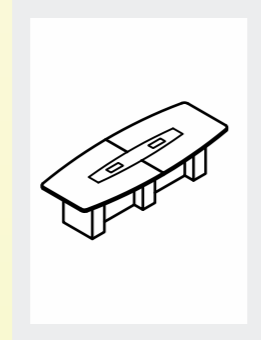

DP-MT-BOLT

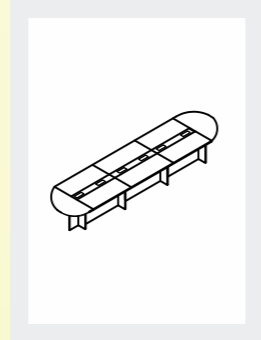

DP-MT-OVAL

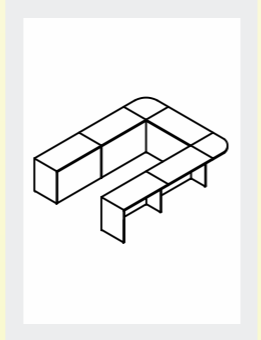

DP-MT-U

# DESKING executive



Office desking system for directors, executive, sr.manager. We have standard models and also customize as per client's requirement. Corian and veneer work also done. Many more design also available.



CAD representation of standard design :

Std. size :  
 1200x600mm  
 1500x750mm  
 1500x600mm  
 1800x750mm  
 1800x900mm  
 2400x900mm  
 & many more

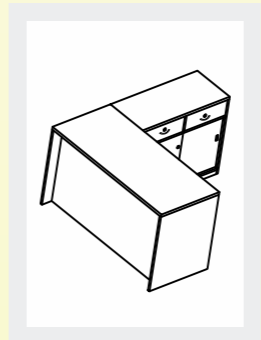

DP-TABLE-STD

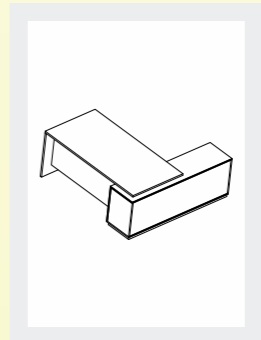

DP-TABLE-CORP

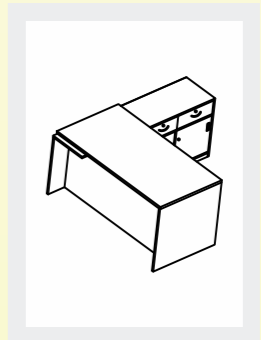

DP-TABLE-AMF

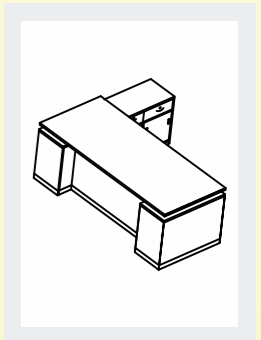

DP-TABLE-DRCT



# FULL HEIGHT PARTITION



FRAME MATERIAL	Powder Coated Aluminum channels
THICKNESS	65mm
HEIGHT	8-12ft
INFILL	Twin tiles, 8-12mm thick prelam particle board or Medium Density Fibre (MDF) board as per IS code no. 12823
OTHER TILE OPTIONS	Plain/Frosted Glass Color Lacquered Glass Fabric Panel Marker Board
WIRE MANAGEMENT	Separate concealed electrical with all four side laminated with all cable provision
FLUSH DOOR	30/32 mm thick both side laminated with all four side pvc/wooden lipping
HARDWARE	1 no. mortice lock 1 no. Door closure 3nos. Stainless steel hinge 1no. Door stopper

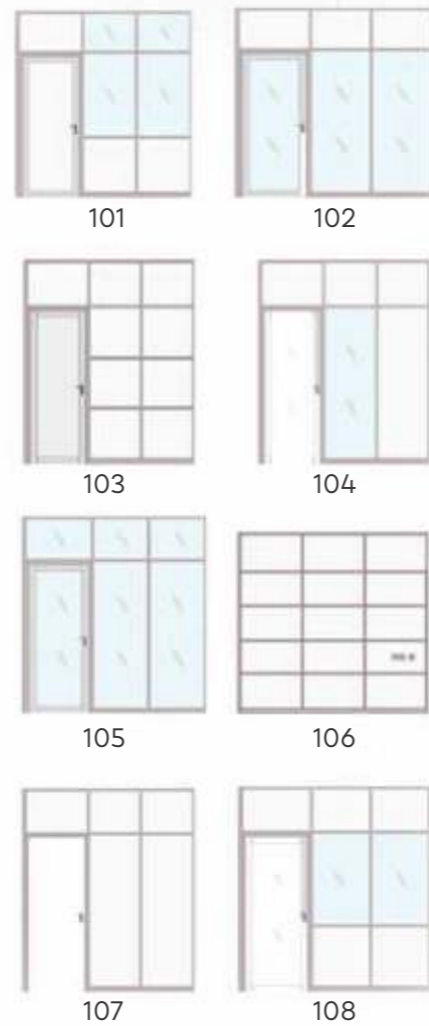

The perfect solution for noise free modular office partition

- Sound insulation-noise free
- Tile based partition system
- High degree of flexibility allows easy reconfiguration of tiles
- Customisable as per site to site requirement
- Faster installation
- Strength & durability
- Rust free, Termite proof
- Wire management easy

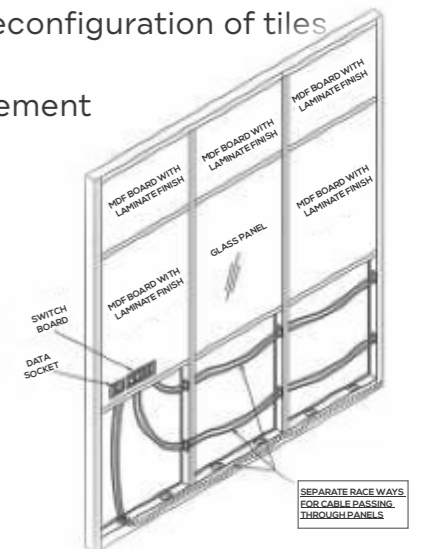

# STORAGE



File cabinet consist of shutter or without shutter, shelf, drawer and necessary hardware will be use for any height and as per space. Also design as per customer's requirement.

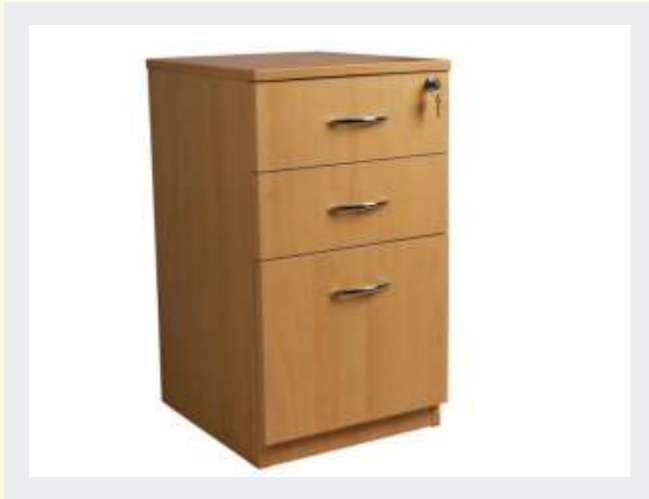

CAD representation of standard design :

Std. size :  
 900X750mm  
 900x1200mm  
 1200x1200mm  
 1500x1200mm  
 900x2400mm

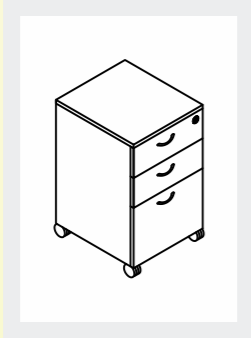

DP-DR-MBL

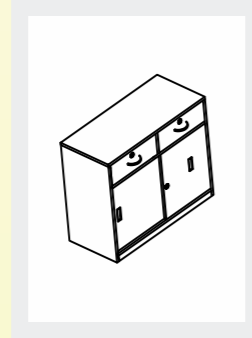

DP-SU

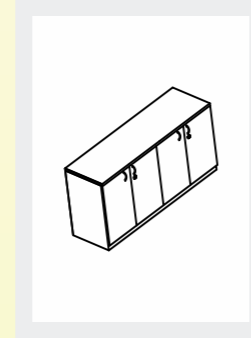

DP-ST-LHS

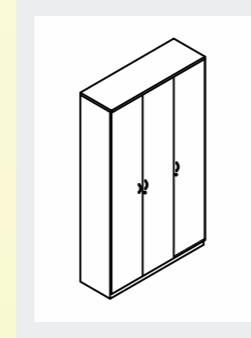

DP-ST-FHS

# INSTITUTIONAL





# CHAIR

# SOFA

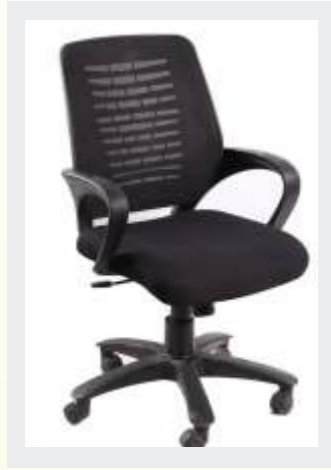

DP-Classic



DP-Zazz/HB



DP-Max



DP-Smart

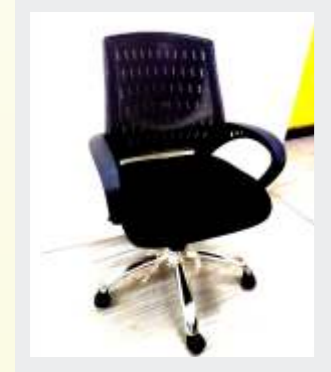

DP-Eco



DP-TC-01



DP-Lash/MB

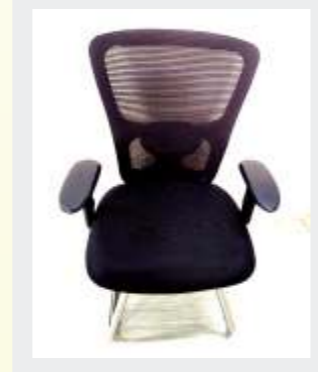

DP-Zazz MB Fix



DP-TC-02



DP-Stylish



DP-Pretty



DP-Smart Fix



DP-Matrix/HB



DP-Diplomat HB



DP-Diplomat MB Fix



DP-Trump HB



DP-Pleasure



DP-Cheers



DP-Kiara



DP-Amelia



DP-Prink



DP-Slim



DP-Sofa/WC



DP-Sofa/C

# HOUSEHOLD solution



We undertake household furniture orders from interior designers, clients for projects.



These are made of prelam/post laminated MDF, particle board and ply board of standard brand. These are all custom made furniture suitable for clients, space. Many more designs available.



# OUR CLIENTS



& Many More